



Quick Service Guide 201b

Commercial Letters and Postcards

Using Tabs, Wafer Seals, and Glue Strips

October 5, 2009

[Printer-Friendly PDF](#)

Overview

Unenveloped letter-size mailpieces prepared for automation mailings must be secured (**tabbed**) to prevent an open edge from jamming high-speed processing equipment. Standards for **tabbing** are based on basis weight of paper stock used and the location of the folded or bound edge. As an alternative to **tabs** or wafer seals, the open edge of the length of the mailpiece may be continuously glued or spot glued. Continuous glue or spot glue is permissible with single-sheet self-mailers and postcards, and specific booklet designs.

Physical Standards (201.3.11)

Number and location of **tabs** or wafer seals are specified for particular types of letter-size mail. In all cases, additional **tabs** may be used.

Tabs, wafer seals, cellophane tape, or permanent glue (continuous or spot) must not interfere with recognition of the barcode, rate marking, postage identification, or required address information. In all cases additional **tabs** or seals may be used. Cellophane tape is not acceptable within the barcode clear zone. **Tabs** or wafer seals placed in the barcode clear zone must contain a paper face meeting the standards for background reflectance and, if the barcode is not preprinted by the mailer, the standards for water-based ink.

Adequate adhesion is required.

Basis weight: the minimum basis weight standards vary, depending on the construction of the mailpiece (see below) and the sheet size below.

Letter-Size Folded Self-Mailers (201.3.14)

Folded edge (bottom) must be parallel to the longest dimension (length) and address of the mailpiece.

With one **tab** or wafer seal: folded edge at bottom of mailpiece, **tab** or wafer seal in middle of top edge of mailpiece.

- Single folded sheet, sealed with one **tab** or wafer seal, minimum basis weight: 28 pounds (17 by 22 inches by 500 sheets) or 70 pounds (25 by 38 inches by 500 sheets).
- Two or more sheets, sealed with one **tab** or wafer seal, minimum basis weight: 24 pounds (17 by 22 inches by 500 sheets) or 60 pounds (25 by 38 inches by 500 sheets).

With two **tabs** or wafer seals: minimum basis weight 20 pounds (17 by 22 inches by 500 sheets) if folded edge is at top or bottom of the mailpiece. **Tabs** or wafer seals must be placed within 1 inch of the right and left edges of mailpiece (see reverse).

With folded edge on right (leading) edge: left (trailing) edge and other open edges must be secured with at least one **tab** or a glue line; additional **tabs** may be required based on trim size and basis weight.

Letter-Size Booklet-Type Mailpiece (201.3.15)

The mailpiece must be **tabbed** (secured) with non perforated 1-1/2" **tabs**, glue, or 1-1/2" wide tape. See DMM [201.3.15](#) for illustrations and design details for booklets.



Postcard (201.3.16)



Minimum basis weight 75 pounds or greater. Double postcards must have folded edge at the top or bottom. The open edge must be secured with one **tab** in the middle.

Placement of **Tab**s and Wafer Seals (201.3.14)

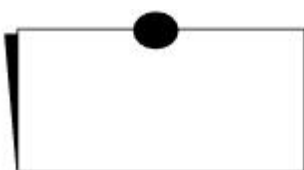
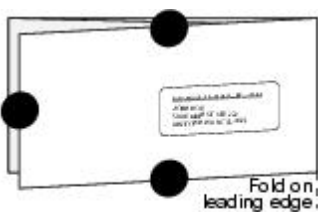

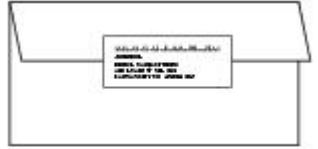
Specifications for Automation-Compatible Letter-Size Mailpieces

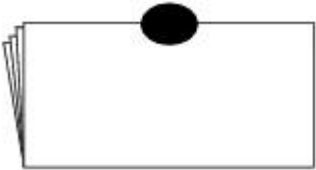
<p>Double Postcard Tabs 1 (middle) Folded Edge Top or Bottom Sheets Single Basis Weight 75 lb.</p>		<p>Folded Self-Mailer Tabs 3 (left and open edges) Folded Edge Right Sheets Single Basis Weight 75 lb.</p>	 <p>Fold on leading edge.</p>
<p>Folded Self-Mailer Tabs 2 (start ≤ 1 inch from edges) Folded Edge Top or Bottom Sheets Single Basis Weight 20 lb.</p>		<p>Folded Self-Mailer (Invitation Fold) Tab Address Label Folds Top and Bottom Sheets Multiple Basis Weight 20 lb.</p>	
<p>Folded Self-Mailer Tabs 1 (middle) Folded Edge Bottom</p>		<p>Folded Self-Mailer (Continuous Glue Strip) Open Edge Top</p>	

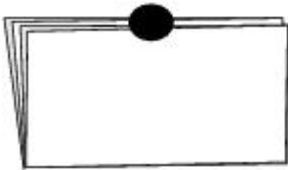
<p>Sheets Multiple Basis Weight 24 lb.</p>		<p>Folded Edge Bottom Sheets Single Basis Weight 20 lb.</p>	
<p>Folded Self-Mailer Tabs 1 (middle) Folded Edge Bottom Sheets Single Basis Weight 28 lb.</p>		<p>An 8-1/2 x 11 inch sheet of 20, 24, or 28 pound paper folded once to 8-1/2 x 5-1/2 inches does not meet the minimum thickness of 0.009 inch for an automation-compatible letter. See DMM 201.3.15 for illustrations and design details for booklets.</p>	

[Back to Top](#)